

INSTRUCTION SHEET Page 2  
TILLOTSON™ CARBURETOR - MODEL HR  
GENERAL EXPLODED VIEW

THE GENERAL DESIGN AND PARTS SHOWN WILL VARY TO  
INDIVIDUAL UNITS COVERED ON THIS INSTRUCTION SHEET

## CLEANING

CLEANING MUST BE DONE WITH CARBURETOR DISASSEMBLED.

SOAK PARTS LONG ENOUGH TO SOFTEN AND REMOVE ALL FOREIGN MATERIAL. USE (1) A CARBURETOR CLEANING SOLVENT, (2) LACQUER THINNER, OR 3) DENATURED ALCOHOL. MAKE CERTAIN THE THROTTLE BORE IS FREE OF ALL CARBON AND VARNISH DEPOSITS. RINSE OFF IN SUITABLE SOLVENT. BLOW OUT ALL PASSAGES IN CASTINGS WITH COMPRESSED AIR AND CHECK CAREFULLY TO INSURE THOROUGH CLEANING OF OBSCURE AREAS.

**CAUTION:** DO NOT SOAK GASKETS OR RUBBER PARTS IN CLEANING SOLVENTS. REASSEMBLY REASSEMBLE IN REVERSE ORDER OR DISSASSEMBLY. NOTE SPECIAL INSTRUCTIONS AND ADJUSTMENTS. SPECIAL INSTRUCTIONS  
WELCH PLUG INSTALLATION - INSTALL PLUG WITH CONVEX SIDE UP. THEN FLATTEN, USING A 5/16" FLAT END PUNCH AND HAMMER. (CORRECTLY INSTALLED WELCH PLUG IS FLAT.) INLET NEEDLE SEAT INSTALL GASKET AND SEAT THEN TIGHTEN TO 40-50 INCH LBS. OF TORQUE. INLET CONTROL LEVER SETTING TO ADJUST BEND TANG.

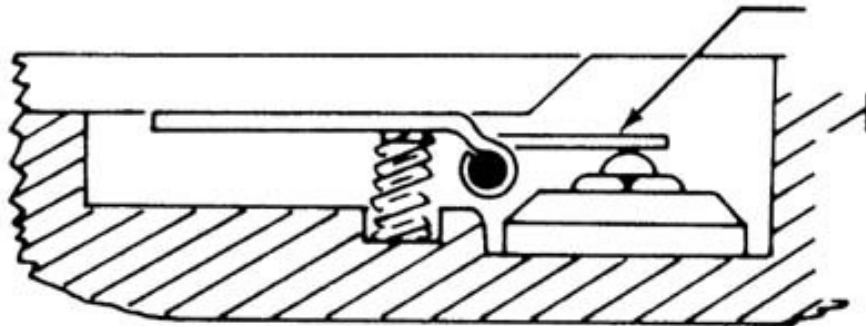

**CAUTION: DO NOT EXERT PRESSURE ON RESILIENT NEEDLE VALVE.** INLET CONTROL LEVER SHOULD BE FLUSH WITH THE METERING CHAMBER WALL. IDLE NEEDLE INSTALLATION - TURN NEEDLE (2) IN LIGHTLY UNTIL SEATED, THEN BACK OUT 1 TURN. IDLE ADJUSTMENT - ENGINE AT OPERATING TEMPERATURE, ADJUST IDLE MIXTURE SCREW TO OBTAIN A SMOOTH STEADY IDLE AND ADJUST IDLE SPEED SCREW TO ENGINE MANUFACTURER'S R.P.M. HIGH SPEED NEEDLE INSTALLATION - TURN NEEDLE (7) IN LIGHTLY UNTIL SEATED, THEN BACK OUT 1 TURN. HIGH SPEED ADJUSTMENT - ENGINE AT FULLY OPEN THROTTLE AND UNDER NORMAL FULL LOAD, ADJUST NEEDLE TO OBTAIN THE HIGHEST R.P.M.